

LL17.75 MK2

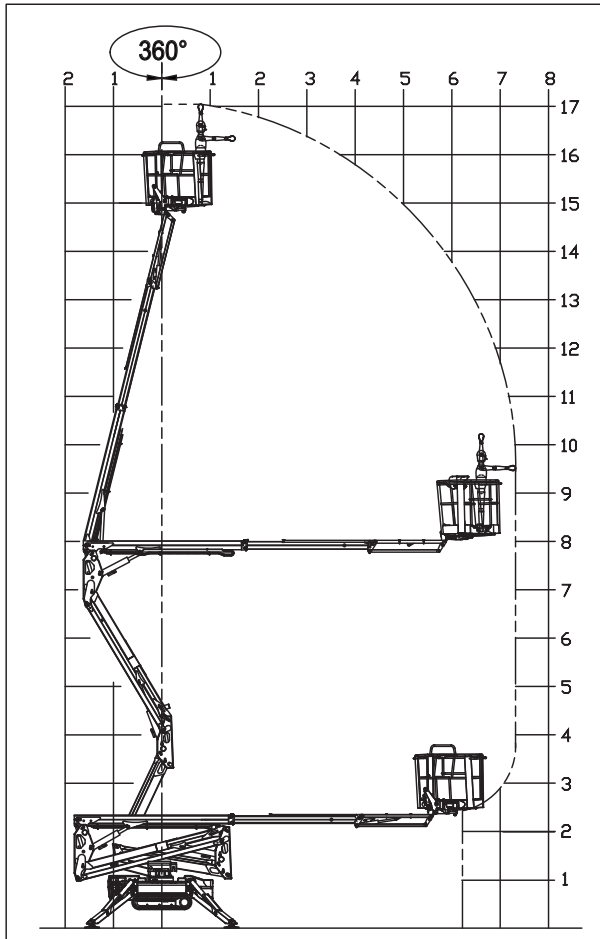

PORTATA MAX 230 KG
(2 persone 80x2=160 kg + attrezzatura 70 kg)

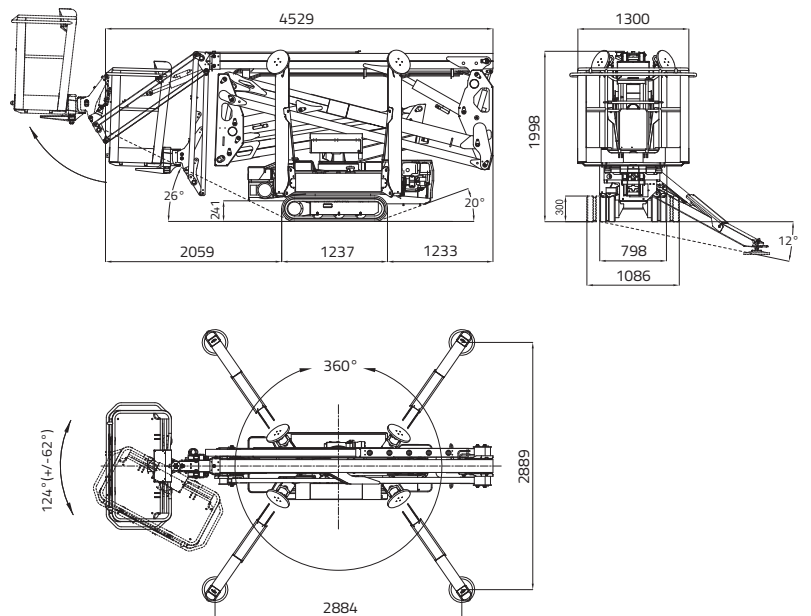

17,06 m



7,50 m



4,53 m



4,17 m



1,99 m



1.335 x 690 x h. 1.100 mm



124° (+/-62°)



16° / 28,7%



798 - 1086 mm



1.731 daN - 2,45 daN/cm²



2.884 x 2.889 mm



Stabiliz. e destabiliz. automatica IIIS di serie



Filocomando



GPRS-GPS



R.A.H.M.



Pacco batterie al litio
4,8 kWh
Opzionale



MOTORE BENZINA

Marca HONDA
 Tipo GX390
 Cilindri e cilindrata monocilindrico
 389 cm³
 Potenza lorda max
 11,7HP - 8,7 kW @ 3600 rpm (GX390)
 Avviamento elettrico 12 volt

MOTORE DIESEL

Marca HATZ
 Tipo 1B40 - HD Autorev
 Cilindri e cilindrata monocilindrico
 462 cm³
 Potenza lorda max
 10 HP - 7,5 kW @ 3600 rpm
 Avviamento elettrico 12 volt

SISTEMA LITHIUM-ION

Pacco batterie al litio 4,8 kWh
 Caricabatterie a bordo
 220V 50Hz o 110V 50Hz
 Autonomia di lavoro 4-5 h
 Tempo di ricarica a batterie completamente
 scariche 4 h (indicativo)
 Tempo di ricarica all'80% da batterie com-
 pletamente scariche 2 h (indicativo)

POMPA IDRAULICA

Motore elettrico 2 ad ingranaggi

CINGOLATURA

Tendicingolo a grasso
 Rulli per lato 3 + slitta

Velocità di traslazione con 3^a velocità Auto2speed:

- motore benzina 0,6 - 1,4 - 2,7 km/h
 - motore diesel 0,7 - 1,8 - 3,6 km/h
 - motore lithium-ion 0,4 - 0,8 - 1,6 km/h

PESO MACCHINA motore termico 2230 kg

PESO MACCHINA lithium-ion 2300 kg

VELOCITÀ MAX VENTO 12,5 m/s